

V8-300/350-C

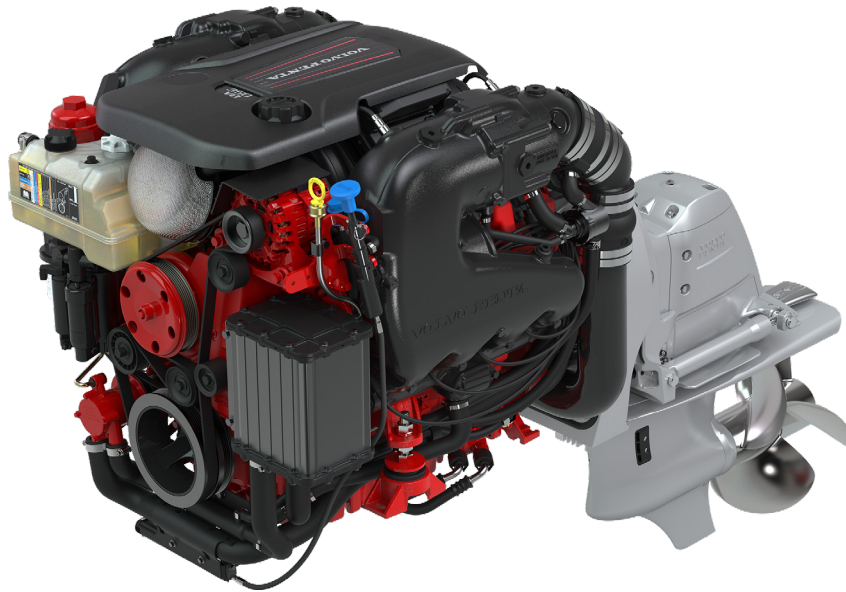

Technical Data

	V8-300-C	V8-350-C
Engine designation	V8-300-C	V8-350-C
Power, kW (hp)	224 (300)	261 (350)
Engine speed, rpm	5800	5800
Displacement, l (in ³)	5.3 (323)	5.3 (323)
Number of cylinders	V8	V8
Bore/stroke, mm (in.)	96/92 (3.80/3.62)	96/92 (3.80/3.62)
Compression ratio	11.0:1	11.0:1
Fuel system	Spark Ignited Direct Injection	Spark Ignited Direct Injection
Volvo Penta Aquamatic drive	SX	1)
Ratio	1.51:1, 1.60:1, 1.66:1	
Volvo Penta Duoprop drive	DPS, DPS OX	DPS, DPS OX
Ratio	1.95:1, 2.14:1, 2.32:1	1.95:1, 2.14:1, 2.32:1
Volvo Penta Forward Drive	FWD, FWD OX	FWD, FWD OX
Ratio	1.95:1, 2.14:1, 2.32:1	1.95:1, 2.14:1, 2.32:1
Dry weight with DP, incl. prop. & PS, kg (lb)	432 (952)	432 (952)
Rating	5 ²⁾	5 ²⁾
The engine complies with	US EPA, CARB, EU RCD II, BSO ³⁾	US EPA, CARB, EU RCD II

1. Not available

2. RATING 5, for pleasure craft applications

3. Single installations only

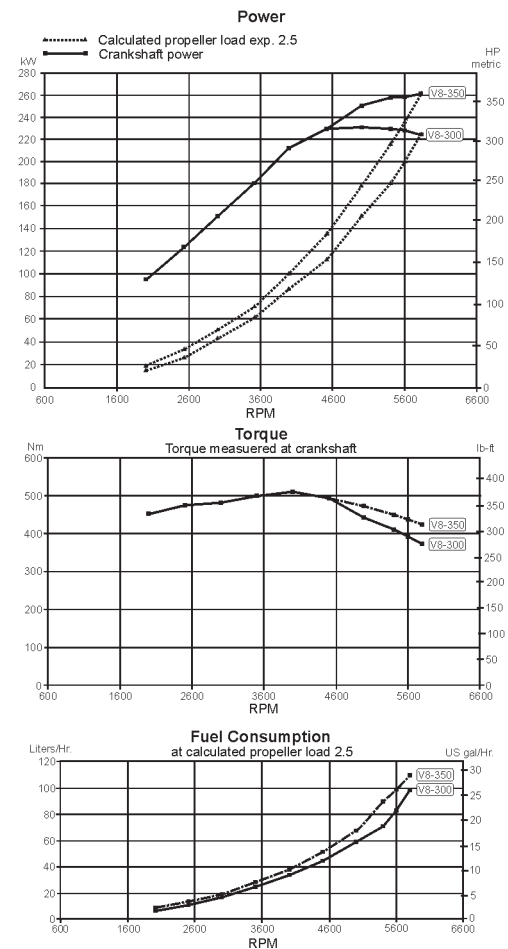

See note, page 2

**VOLVO
PENTA**

V8-300/350-C

Technical description:

Engine block and head

- Aluminum, deep skirt cylinder block with six bolt, powdered metal main caps for extra strength
- Hydraulic cam phaser for variable camshaft timing optimizes low end torque and high-end horse power

Lubrication system

- Pressure lubrication system with heavy duty engine oil cooler and remote oil filter
- Paper oil filter element reduces environmental impact of engine service
- Cast aluminum structural oil pan

Fuel system

- Spark Ignited Direct Injection system with stainless steel returnless fuel rail and highpressure mechanical fuel pump
- High pressure direct injection facilitates a higher compression ratio and improved combustion
- Vapor separating fuel pump system with two electric pumps, pressure regulator, and water separating fuel filter

Intake and exhaust system

- Low weight aluminum exhaust system
- Three inch riser option is a direct replacement for the standard height elbow

- Exhaust passages optimized for torque and power
- Collector (elbow) design maximizes use of the catalyst for reduced back pressure

Cooling system

- Equipped with **Easy Drain**, a one-point draining system for the raw-water portion of the cooling system
- Freshwater (closed) cooling system for engine and engine oil cooler
- Advanced Volvo VCS (yellow) coolant for superior corrosion and thermal protection

Ignition system

- Iridium tipped, side electrode spark plugs for reliability and extended service life
- Coil near plug ignition system

Electronic engine control

- Electronic Control Module (ECM) ensures constant, optimum performance, greater fuel efficiency and reduced emissions
- 4G ECM supports full diagnostics through connection on engine harness
- Closed loop system with pre- and post catalyst oxygen sensors helps control fuel delivery and reduce emissions

Electrical system

- 12V corrosion-protected electrical system
- 120A marine alternator with internal transistorized voltage regulator
- Re-settable circuit breaker for trim system
- Fuse protection of the electric fuel pumps and the fuel injection system
- Auxiliary stop switch in front of engine

Drive

- Silent shift for smoother shifting
- Pattern-matched spiral bevel gears
- Exhaust through propeller hub, cavitation plate
- Break-away coupling between vertical shafts
- Standard tilt specification 52° (42° and 32° available as option on engine order)
- Built-in kick-up function to reduce damage, in the event the drive strikes an underwater object
- Easy access drive and transom shield anodes
- Easily accessible TSK mounted flush port

OX drive features

- Water in bellows sensor
- Drive oil level sensor
- Drive water in oil sensor
- Titanium ceramic corrosion protective coating

Power trim

- High capacity trim pump integrated with transom shield to ease installation and save space in engine compartment

Accessories

- Sea strainer kit
- Easy Connect
- Air Conditioner Kit

Dimensions V8-300/DPS

Not for installation

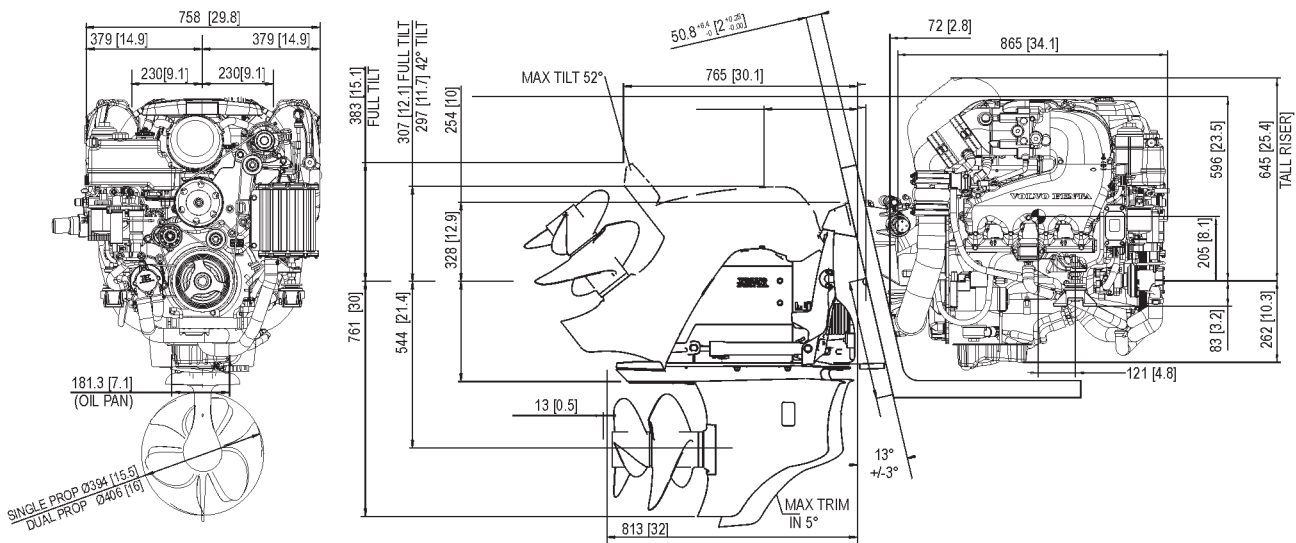

More information

Contact your nearest Volvo Penta dealer for more information about Volvo Penta engines and optional equipment/accessories or go to www.volvopenta.com



IOS



Android

Download the Volvo Penta dealer locator App for your iPhone or Android

Note: Power and fuel consumption measurements according to ISO 8665. Fuel octane of 90 RON (87 AKI) with 0% ethanol and density of 742g/liter, air temperature at 25°C (77°F), humidity of 30% and barometric pressure at 100 kPa (14.5 PSI). Operation at different conditions will influence engine power output and fuel consumption.

VOLVO PENTA

AB Volvo Penta

SE-405 08 Göteborg, Sweden
www.volvopenta.com

Not all models, standard equipment and accessories are available in all countries. All specifications are subject to change without notice. The engine illustrated may not be entirely identical to production standard engines.